

# AutoCAD® Electrical Work-Flow-Based Training Course Syllabus (IEC standards)

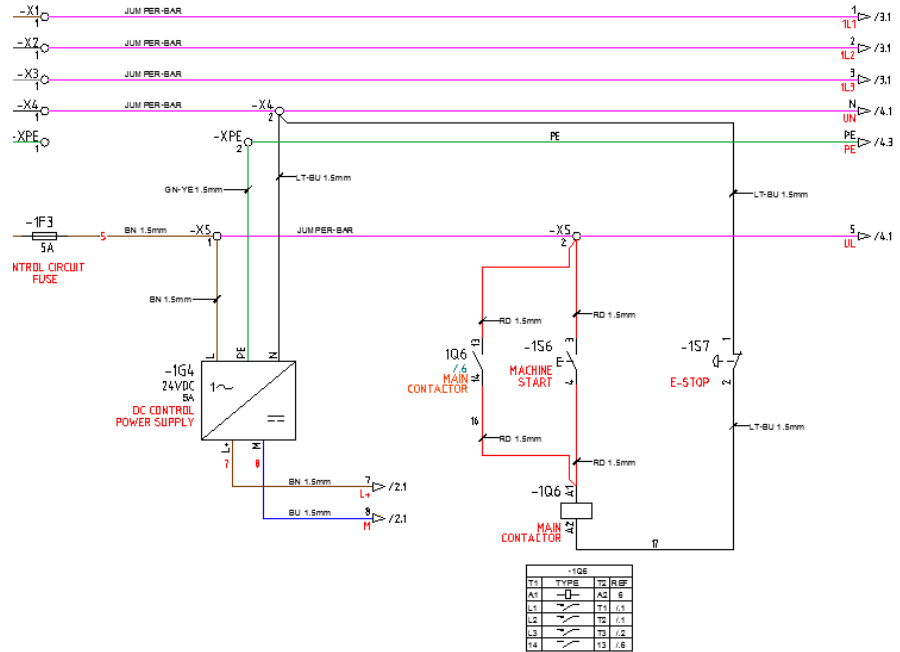

## Day One:

- Basic hands-on functional overview of AutoCAD Electrical
- Program Infrastructure
- Working in a network environment
- Configuration
- Customization
- Creating the "Smart" Border Template with pre-loaded design rules and wire types



## Day Two:

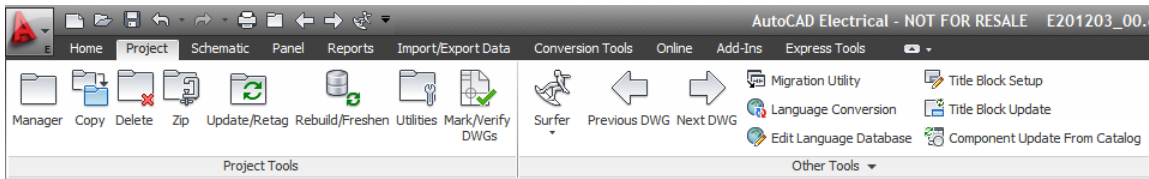

- Project Management
- Managing wires and power distribution buses
- Inserting a terminal strip
- Editing attribute location, size, visibility
- 3-phase parametric devices
- Managing the pin list database
- Move a component to a new location
- Define a wiring sequence
- Define a subassembly
- Advanced attribute management
- Advanced scot
- Creating a control circuit

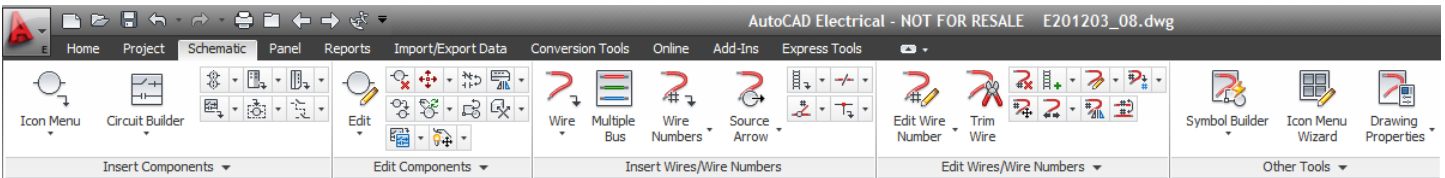



## Day Three:

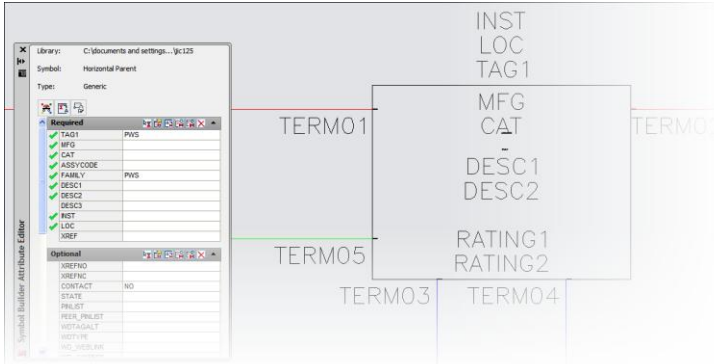

- Create a custom schematic symbol
- Add a new symbol to the icon menu
- Add a new submenu to the icon menu
- Add a new vendor part number to the catalog database
- Create a latching circuit
- Automatic cross-referencing
- Using the Schematic Surfer for a design review
- Copy a circuit
- Swap a Block

- Assign wire numbers automatically
- Create a 3-phase motor circuit
- Insert location boxes (working with Installation and Location codes)
- Insert a terminal strip across multiple wires automatically
- Creating and using saved circuits
- Renumber a terminal strip automatically with the Terminal Strip Editor



## Day Four:

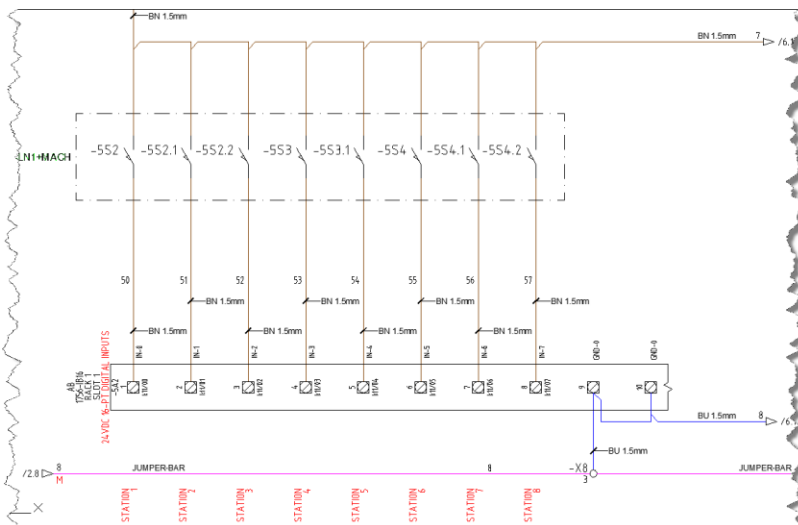

- Insert a PLC power supply
- Insert a PLC processor
- Insert a parametrically built PLC input module
- Insert multiple component symbols automatically
- Using the align tool
- Using the find/edit/replace editing tool
- Editing and updating schematic data using Microsoft® Excel
- Move all I/O address descriptions simultaneously
- Insert a parametrically built PLC output module

- Insert a Form-C control relay and contacts with automatic pin assignments and cross-referencing
- Insert a selector switch
- Insert a connector using the parametric connector builder



## Day Five:

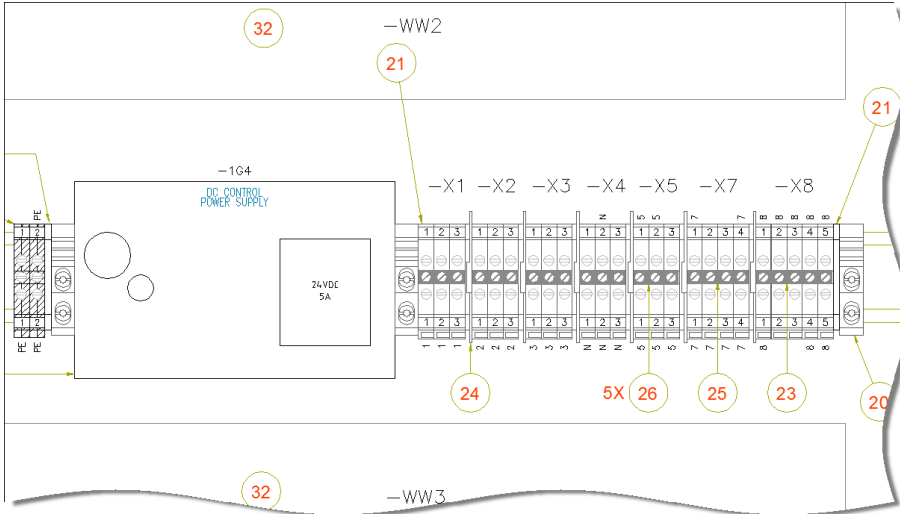

- Create a Panel Layout from a list of schematic components
- Manage the footprint lookup database
- Automated nameplate insertion
- Bi-directional updates
- Assign item numbers automatically
- Inserting balloons
- Create a custom panel layout symbol (footprint)
- Annotating footprints with wire numbers
- Managing DIN rails and wire-ways
- Inserting graphical terminal strips

- Insert multiple footprints automatically
- Error Analysis in preparation for release
- Automatic Report Generation

ITEM	TAG(S)	QTY	MFG	CATALOG	DESCRIPTION
1	-1S6 -1S7 -2P2 -2P4 -2S2 -2S2.1 -2S2.2 -2S4 -2S4.1	11	AB	800T-X59E	Name Plate 800T Half Round Gray Custom Text
2	L1				
3	N				
4	PE				

WIRE NO.	WIRE TYPE	CBL	CBL CORE	CBL LOC	CBL MFG	CBL CAT	LOC FROM	COMP FROM	LOC TO	COMP TO
L1	bn_4.0mm^2						MPNL -1Q1:1:1	MPNL -1Q1:1:1	MPNL -X0:L1	
L2	bk_4.0mm^2						MPNL -1Q1:1:3	MPNL -1Q1:1:3	MPNL -X0:L2	
L3	gy_4.0mm^2						MPNL -1Q1:1:5	MPNL -1Q1:1:5	MPNL -X0:L3	
N	lt-bu_1.5mm^2						MPNL -X4:3	MPNL -X4:3	MPNL -4G2	
N	lt-bu_4.0mm^2						MPNL -X4:1	MPNL -X4:1	MPNL -X0:N	
N	lt-bu_1.5mm^2						MPNL -X4:2	MPNL -X4:2	MPNL -1G4:N	
N	lt-bu_1.5mm^2						MPNL -X4:2	MPNL -X4:2	MPNL -1S7:1	
PE	gn-ye_4.0mm^2						MPNL -X0:PE	MPNL -X0:PE	MPNL -XPE:1	
PE	gn-ye_1.5mm^2						MPNL -1G4:PE	MPNL -1G4:PE	MPNL -XPE:2	
PE	gn-ye_1.5mm^2						MPNL -XPE:2	MPNL -XPE:2	MPNL -4G2	
1	bn_4.0mm^2						MPNL -1Q6:T1	MPNL -1Q6:T1	MPNL -X1:1	
1	bn_2.5mm^2						MPNL -X1:2	MPNL -X1:2	MPNL -3F2	
1	bn_2.5mm^2						MPNL -X1:3	MPNL -X1:3	MPNL -3F4	
2	bk_4.0mm^2						MPNL -1Q6:T2	MPNL -1Q6:T2	MPNL -X2:1	
2	bk_2.5mm^2						MPNL -X2:2	MPNL -X2:2	MPNL -3F2	
2	bk_2.5mm^2						MPNL -X2:3	MPNL -X2:3	MPNL -3F4	
3	gy_4.0mm^2						MPNL -1Q6:T3	MPNL -1Q6:T3	MPNL -X3:1	
3	gy_2.5mm^2						MPNL -X3:2	MPNL -X3:2	MPNL -3F2	

**Note:** Day 2 of this course begins a “from scratch” design simulation and builds upon the content developed during Day 1. This course is workflow-based so the attendees will experience each phase of a new design while exploring the many automated and semi-automated tools available in AutoCAD® Electrical. This course is especially suitable for those who will only be able to attend one course, yet must return to their office to implement and manage the software on their own. If you only have time and finances to attend one AutoCAD Electrical training course, this is the one to attend. The instructor has been designing PLC-based control systems to meet NFPA/UL and DIN/IEC standards since 1988, with an installed base of systems numbering into the thousands globally.